

with encoder housing

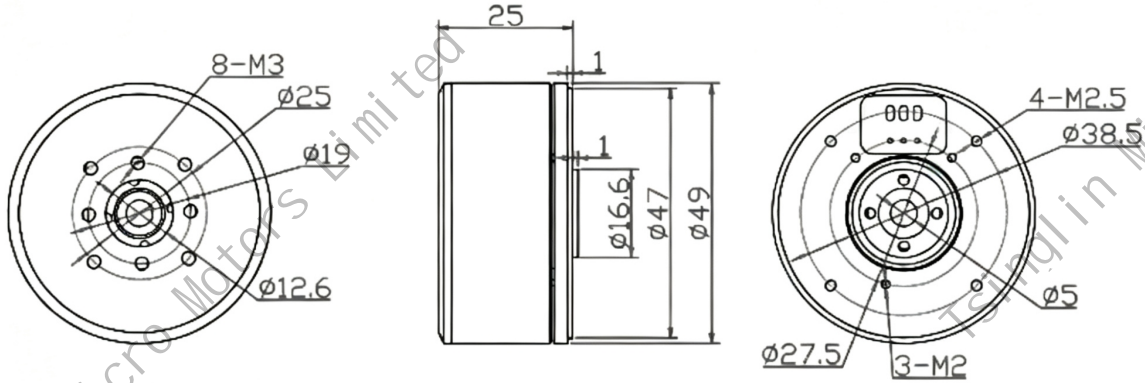

without encoder housing

参数 Parameters	单位 Unit	GB4315
额定电压 (Nominal voltage)	V	24
额定电流 (Nominal current)	A	0.59
额定扭矩 (Nominal torque)	N. M	0.28
额定转速 (Nominal Speed)	RPM	238
最大转速 (Max Speed)	RPM	660
堵转扭矩 (Stall torque)	N. M	0.42
堵转电流 (Stall current)	A	0.9
绕线匝数 (Winding turns of motor)	T	60
相电阻 (Phase resistance)	Ω	15.2
相电感 (Phase inductance)	mH	6.56
转速常数 (Speed constant)	rpm/v	23
扭矩常数 (Torque constant)	N. M/A	0.47
转子惯量 (Rotor inertia)	gcm ²	268
极对数 (Number of pole pairs)	Pairs	14
电机重量不带编码器 (Motor weight without Encoder)	g	161
电机重量带编码器 (Motor weight with Encoder)	g	179.2
编码器类型 (Encoder type)	/	AS5048a/AS5600
工作温度范围 (Working temperature)	°C	20~80
最高退磁温度 (Max demagnetize temperature)	°C	120